



RoHS compliant
1550 nm Single-mode XFP Transceiver up to 40km link length
10GBASE-EW/ER(Ethernet)



Features

- Compliant with IEEE802.3ae 10GBASE-EW/ER
- Supports 9.95Gb/s to 11.1Gb/s bit rates
- Ethernet
- Compliant with XFP MSA INF-8077i
- Differential LVPECL inputs and CML outputs
- TTL signal detect indicator
- Hot Pluggable
- Class 1 laser product complies with EN 60825-1

Ordering Information

PART NUMBER	INPUT/OUTPUT	SIGNAL DETECT	VOLTAGE	TEMPERATURE
CL-XFP-ER-40	AC/AC	TTL	3.3V	0°C to 70 °C
CL-XFP-ER-40i	AC/AC	TTL	3.3V	-40°C to 85 °C

Absolute Maximum Ratings

PARAMETER	SYMBOL	MIN	MAX	UNITS	NOTE
Storage Temperature	T_s	-40	85	°C	
Supply Voltage	V_{cc3}	-0.5	4.0	V	
	V_{cc5}	-0.5	6.0	V	
	V_{cc-5}	-6	0.5	V	



RoHS compliant
1550 nm Single-mode XFP Transceiver up to 40km link length
10GBASE-EW/ER(Ethernet)

Recommended Operating Conditions

PARAMETER	SYMBOL	MIN	MAX	UNITS	NOTE
Case operating Temperature	T_C	0	70	°C	
Supply Voltage	V_{cc3}	3.1	3.5	V	
Supply Current	I_{cc3}	---	300	mA	
Supply Voltage	V_{cc5}	4.5	5.5	V	
Supply Current	I_{cc5}	---	600	mA	
Supply Voltage	V_{cc-5}	-4.5	-5.5	V	
Supply Current	I_{cc-5}	---	100	mA	

Transmitter Electro-optical Characteristics

$V_{cc3} = 3.1\text{ V to }3.5\text{ V}$, $V_{cc5} = 4.5\text{ V to }5.5\text{ V}$, $V_{cc-5} = -5.5\text{ V to }-4.5\text{ V}$, $T_C = 0\text{ °C to }70\text{ °C}$

PARAMETER	SYMBOL	MIN	TYP.	MAX	UNITS	NOTE
Operating Data Rate			9.95/ 11.1		Gbps	
Input Reference Clock Rate			No Required			
Output power	P_{out}	-4		4.7	dBm	
Extinction Ratio	ER	6			dB	
Center Wavelength	λ_C	1530		1565	nm	
Sidemode Supression ratio	SSR_{min}	30				dB
Relative Intensity Noise	RIN	---	---	-130	dB/Hz	
Output Eye			Compliant with IEEE802.3ae			
Differential Input Voltage	V_{DIFF}	0.12	---	1.0	V	
Transmit Fault Output-Low	TX_FAULT_L	0.0	---	0.5	V	
Transmit Fault Output-High	TX_FAULT_H	2.4	---	V_{CC}	V	
TX_DISABLE Assert Time	t_{off}	---	---	10	μs	
TX_DISABLE Negate Time	t_{on}	---	---	2	ms	
Time to initialize	t_{init}	---	---	300	ms	



RoHS compliant
1550 nm Single-mode XFP Transceiver up to 40km link length
10GBASE-EW/ER(Ethernet)

Interrupt assert delay	Interrupt_on	---	---	200	ms
Interrupt negate delay	Interrupt_off	---	---	500	μ s
P_Down/RST assert delay	P_Down/RST_on			100	μ s
Mod_NR assert delay	Mod_nr_on			1	ms
Mod_NR negate delay	Mod_nr_off			1	ms
P-Down reset time		10			μ s
RX_LOS assert delay	t_loss_on			100	μ s
RX_LOS negate delay	t_loss_off			100	μ s



RoHS compliant
 1550 nm Single-mode XFP Transceiver up to 40km link length
 10GBASE-EW/ER(Ethernet)

Receiver Electro-optical Characteristics

$V_{cc3} = 3.1\text{ V to } 3.5\text{ V}$, $V_{cc5} = 4.5\text{ V to } 5.5\text{ V}$, $V_{cc-5} = -5.5\text{ V to } -4.5\text{ V}$, $T_C = 0^\circ\text{C to } 70^\circ\text{C}$

PARAMETER	SYMBOL	MIN	TYP.	MAX	UNITS	NOTE
Receiver Sensitivity		-16		-1	dBm	BER < 10^{-12}
Receiver Sensitivity (OMA)	P_{IN}	---	---	-14.1	dBm	BER < 10^{-12}
Stressed Receiver Sensitivity (OMA)	P_{IN}	---	---	-11.3	dBm	BER < 10^{-12}
Operating Center Wavelength	λ_C	1270	---	1600	nm	
Receiver Reflectance	R_{rx}	27	---	---	dB	
Dispersion Penalty				2	dB	40 km
Loss of Signal-Asserted	P_A	---	---	-30	dBm	
Loss of Signal-Deasserted	P_D	-22	---	---	dBm	
Differential Output Voltage	V_{DIFF}	0.6		0.8	V	
TTL Input High Voltage		2		V_{cc}	V	
TTL Input Low Voltage		0		0.8	V	
TTL Output High Voltage		2.4	---	V_{cc}	V	
TTL Output Low Voltage		0	---	0.4	V	
Receiver Loss of Signal Assert Time (off to on)	t_{A,RX_LOS}	---	---	100	μs	
Receiver Loss of Signal Assert Time (on to off)	t_{D,RX_LOS}	---	---	100	μs	



RoHS compliant
1550 nm Single-mode XFP Transceiver up to 40km link length
10GBASE-EW/ER(Ethernet)

Block Diagram of Transceiver

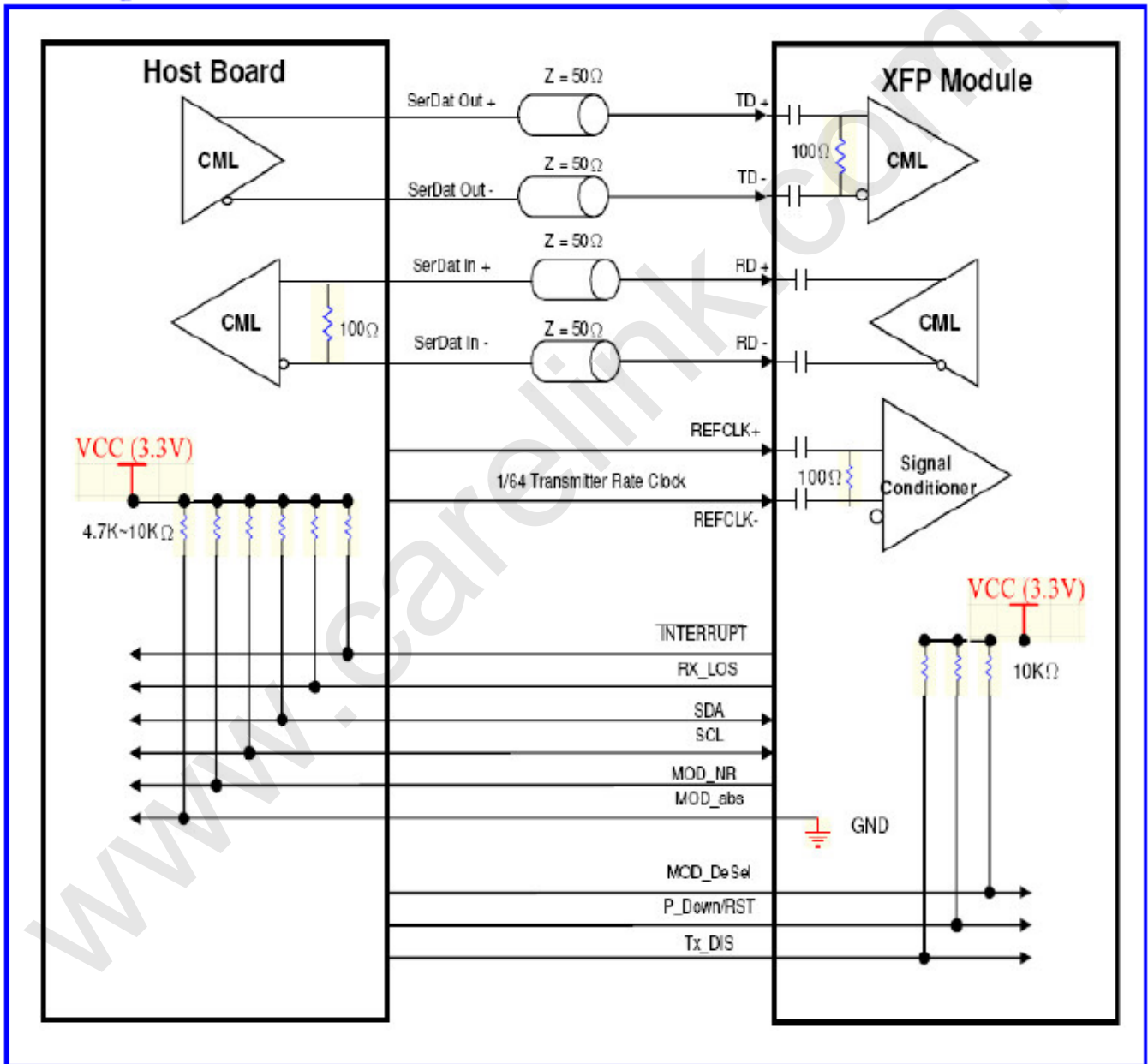



RoHS compliant
1550 nm Single-mode XFP Transceiver up to 40km link length
10GBASE-EW/ER(Ethernet)

MOD_DESEL

The Mod_DeSel is an input pin. When held Low by the host, the module responds to 2-wire serial communication commands. The Mod_DeSel allows the use of multiple XFP modules on a single 2-wire interface bus. When the Mod_DeSel pin is “High”, the module shall not respond to or acknowledge any 2-wire interface communication from the host.

INTERRUPT

Interrupt is an output pin. When “Low”, indicates possible module operational fault or a status critical to the host system.

TX_DIS

TX_DIS is an input pin. When TX_DIS is asserted High, the XFP module transmitter output must be turned off.

MOD_ABS

Mod_ABS is pulled up to Host_Vcc on the host board and grounded in the XFP module. Mod_ABS is then asserted “High” when the XFP module is physically absent from a host slot.

RX_LOS

The RX_LOS when High indicates insufficient optical power for reliable signal reception.

P_Down/RST

This is a multifunction pin for module Power Down and Reset. The P_Down/RST pin must be pulled up to VCC3 in the XFP module.

POWER DOWN FUNCTION

The P_Down pin, when held High by the host, places the module in the standby (Low Power) mode with a maximum power dissipation of 1.5W. This protects hosts which are not capable of cooling higher power modules which may be accidentally inserted.



RoHS compliant
1550 nm Single-mode XFP Transceiver up to 40km link length
10GBASE-EW/ER(Ethernet)

Dimensions

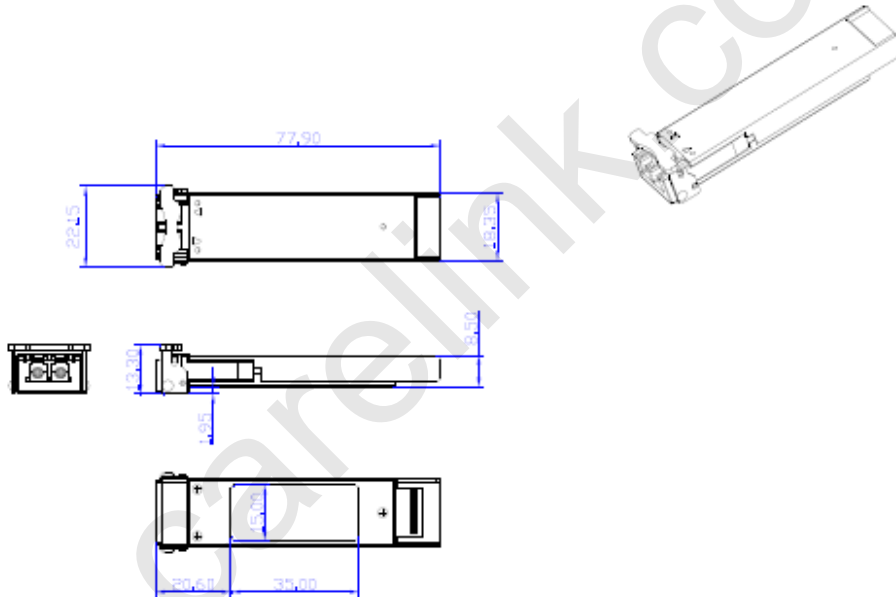

DIMENSIONS ARE IN MILLIMETERS

ALL DIMENSIONS ARE $\pm 0.2\text{mm}$ UNLESS OTHERWISE SPECIFIED



RoHS compliant
1550 nm Single-mode XFP Transceiver up to 40km link length
10GBASE-EW/ER(Ethernet)

www.carelink.com.hk



RoHS compliant
1550 nm Single-mode XFP Transceiver up to 40km link length
10GBASE-EW/ER(Ethernet)

Pin Assignment

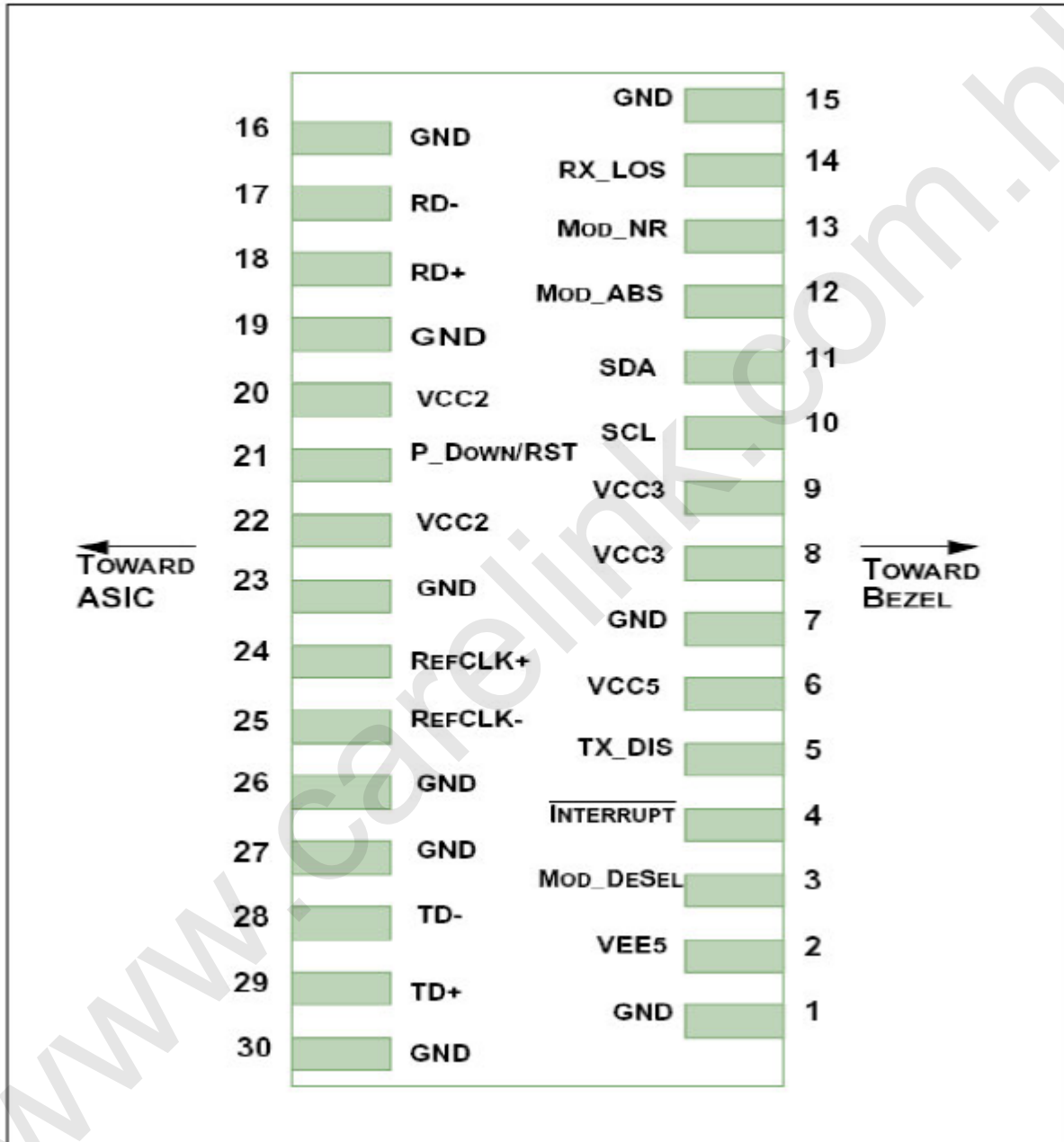



RoHS compliant
1550 nm Single-mode XFP Transceiver up to 40km link length
10GBASE-EW/ER(Ethernet)

<i>Pin</i>	<i>Logic</i>	<i>Symbol</i>	<i>Name/Description</i>	<i>Note</i>
1		GND	Module Ground	1
2		VEES	Optional -5.2V Power Supply	
3	LVTTL-I	Mod_DeSel	Module De-select; When held low allows module to respond to 2-wire serial interface	
4	LVTTL-O	Interrupt	Interrupt; Indicates presence of an important condition which can be read over the 2-wire serial interface	2
5	LVTTL-I	TX_DIS	Transmitter Disable; Turns off transmitter laser output	
6		VCC5	+5V Power Supply	
7		GND	Module Ground	1
8		VCC3	+3.3V Power Supply	
9		VCC3	+3.3V Power Supply	
10	LVTTL-I/O	SCL	2-Wire Serial Interface Clock	2
11	LVTTL-I/O	SDA	2-Wire Serial Interface Data Line	2
12	LVTTL-O	Mod_Abs	Indicates Module is not present. Grounded in the Module	2
13	LVTTL-O	Mod_NR	Module Not Ready; Indicating Module Operational Fault	2
14	LVTTL-O	RX_LOS	Receiver Loss Of Signal Indicator	2
15		GND	Module Ground	1
16		GND	Module Ground	1
17	CML-O	RD-	Receiver Inverted Data Output	
18	CML-O	RD+	Receiver Non-Inverted Data Output	
19		GND	Module Ground	1
20		VCC2	+1.8V Power Supply	3
21	LVTTL-I	P_Down/RST	Power down; When high, requires the module to limit power consumption to 1.5W or below. 2-Wire serial interface must be functional in the low power mode. Reset; The falling edge initiates a complete reset of the module including the 2-wire serial interface, equivalent to a power cycle.	
22		VCC2	+1.8V Power Supply	3
23		GND	Module Ground	1
24	PECL-I	RefCLK+	Reference Clock Non-Inverted Input, AC coupled on the host board	
25	PECL-I	RefCLK-	Reference Clock Inverted Input, AC coupled on the host board	
26		GND	Module Ground	1
27		GND	Module Ground	1
28	CML-I	TD-	Transmitter Inverted Data Input	
29	CML-I	TD+	Transmitter Non-Inverted Data Input	
30		GND	Module Ground	1

1. Module ground pins Gnd are isolated from the module case and chassis ground within the module.
2. Shall be pulled up with 4.7K-10Kohms to a voltage between 3.15V and 3.45V on the host board.
3. The 1.8 V power supply can be optionally programmed to voltages lower than 1.8 V in modules supporting the variable power supply.



RoHS compliant
1550 nm Single-mode XFP Transceiver up to 40km link length
10GBASE-EW/ER(Ethernet)

Eye Safety Mark

The LM2 series multi-mode transceiver is a class 1 laser product. It complies with EN 60825-1 and FDA 21 CFR 1040.10 and 1040.11. In order to meet laser safety requirements the transceiver shall be operated within the Absolute Maximum Ratings.

Caution

All adjustments have been done at the factory before the shipment of the devices. No maintenance and user serviceable part is required. Tampering with and modifying the performance of the device will result in voided product warranty.

Required Mark

Class 1 Laser Product
Complies with
21 CFR 1040.10 and 1040.11

Note : All information contained in this document is subject to change without notice.